

MBA-A

Forca a compasso con denti autolivellanti Automatic crane fork with self levelling ends

Volantino di bloccaggio
Adjustment handwheel

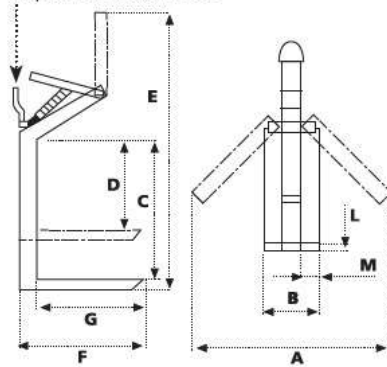

- Pratica regolazione fino all'apertura desiderata
- Bloccaggio di chiusura funzionale e maneggevole mediante apposito volantino
- Ridotte dimensioni di ingombro e sempre inferiori al carico portato
- Forca a bilanciamento automatico a molla
- Designed and constructed in high quality steel to ensure complete safety in compliance with ECC and UNI/EN certifications
- Easy adjustment for opening to desired width
- Closing lock operated and controlled by means of a handwheel
- Automatic adjustment to compensate for the different weight carried



COD. ART. MODEL	PORTATA (Kg) CAPACITY (Kg)	DIMENSIONI - DIMENSIONS (mm)									PESO (Kg) WEIGHT (Kg)
		A	B	C*	D	E	F	G	L	M	
MBA-06A	600	1600	340	1300	1200	2360	1080	1000	25	80	95
MBA-10A	1000	1600	340	1300	1200	2360	1080	1000	25	90	120
MBA-15A	1500	1600	340	1300	1200	2360	1080	1000	30	90	130
MBA-20A	2000	1600	340	1300	1200	2360	1080	1000	35	100	150
MBA-25A	2500	1600	340	1300	1200	2360	1090	1000	35	120	180
MBA-30A	3000	1600	340	1300	1200	2360	1090	1000	35	120	185

C* Altezza utile di carico
Useful loading height